

RAISED FLOOR INSTALLATIONS

Structural supports for raised floor trench heater installations offer stable and effective solutions. Structural supports are manufactured from non-lacquered steel and are suitable for raised floors of a depth up to 500 mm. Structural supports are suitable for **Optimal FKO** and **Basic FKB** models.

SZP-03 low raised floor support

Trench heaters are fitted with reinforcing bars and set screws, which enable the trench heater to be installed at the required height. Set screws must be anchored to the floor to prevent movement. Reinforcing bars are not included as standard and cannot be fitted subsequently. The screws allow setting a maximum height which is max. 30 mm higher than the trench heater itself. Recommended for raised floors with a **maximum depth 30 mm** greater than the unit height of the trench heater.

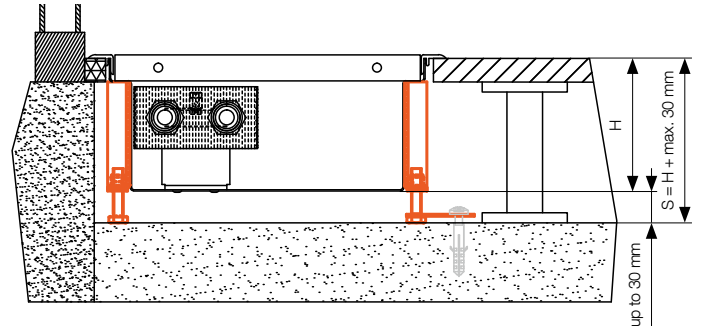

SZP-10 higher raised floor support

Customized solutions for all projects dealing with higher raised flooring. This is a more robust version of the low raised floor support, equipped with one support at the bottom of the trench heater. The precise technical design depends on customer's requirements. Recommended for raised floors with a **maximum depth 100 mm** greater than the unit height of the trench heater.

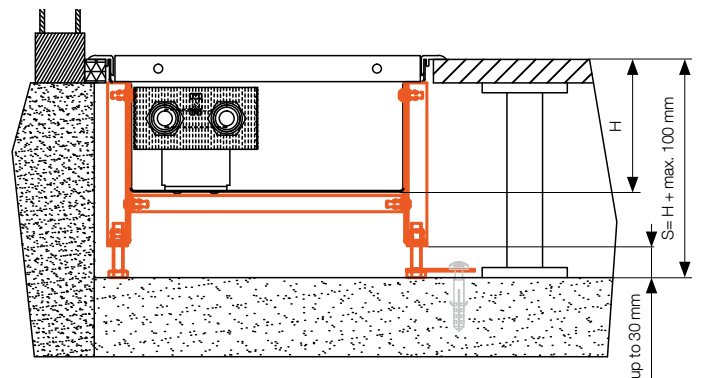

SZP-30 high raised floor support

Customized solutions for all projects dealing with high raised flooring. This is a reinforced version of the higher raised floor support, equipped with two supports at the bottom of the trench convector. The precise technical design depends on customer's requirements. Recommended for raised floors with a **maximum depth 300 mm** greater than the unit height of the trench heater.

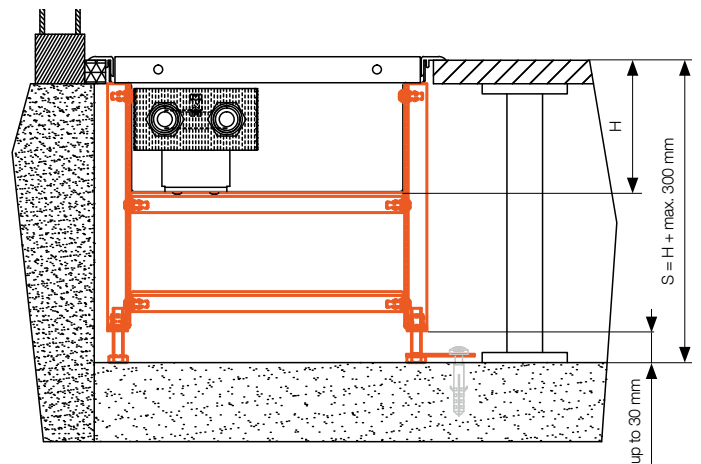

ORDER CODE

Support	Raised	Floor	Support version	Trench heater model	Depth (cm)	Width (cm)	Raised floor height S (cm)	Recommended number of supports (ks)	Convector length (mm)	Recommended number of supports
S	Z	P	-	FK-	-	-	-	-	800-1000	3
									1100-1500	4
									1600-2000	5
									2100-2500	6
									2600-3000	7

Example order code:
SZP-03-FK-11/20-13-5

Raised floor supports for a FK trench heater with natural convection 11 cm deep and 20 cm wide and for raised floor 13 cm deep. The trench heater is 1800 mm long, therefore the raised floor support set for this trench heater consist of 5 supports.

 Supports must be ordered together with trench heaters due to structural alterations to convector casings! Components of several types of raised floor support are integral parts of the trench heater body.

